

# TRANSFORMATIONS ON PETRI NETS IN COLOR TROPIC

## Problem

- Model transformation languages are **the crucial prerequisite** for Model-Driven Engineering (MDE) allowing, in a first phase, the **specification of transformations** from elements of a **source metamodel** to elements of a **target metamodel** and, in a second phase, the automatic **execution** thereof on the underlying models
- The **specification phase**, on the one hand, is often supported by rather **low-level language concepts** leading to time-consuming and faulty transformation specifications
- In the **execution phase**, on the other hand, **the operational semantics** of model transformations often remains **unclear** since the execution takes place on a considerable lower level of abstraction than specification leading to non-transparent transformation executions

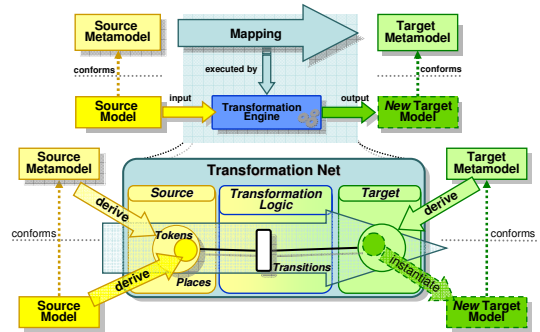

## Goals

- The **specification phase** should be supported by appropriate **abstraction mechanisms** and **reuse facilities** to increase **productivity** of transformation development and to ensure the **quality** of the resulting transformations
- The **execution phase** should be facilitated by a suitable representation of the **runtime characteristics** of a transformation together with **debugging services** to enhance **understandability** of transformations and to improve their **correctness**
- The concepts developed for the execution phase should be **applicable** to certain selected **existing model transformation languages** such as OMG's Query/View/Transformation (QVT) standard to benefit from the debugging services of our approach

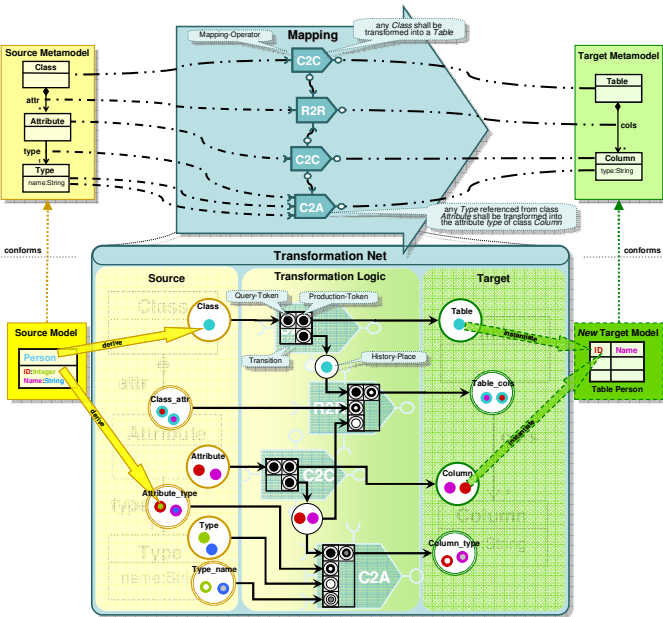

## Approach

- The **specification phase** will be supported by a dedicated **mapping view** offering generic mapping operators organized in an extensible mapping operator library derived from diverse model transformation scenarios
- The **execution phase** will be supported by an **explicit runtime model** based on a variant of Coloured Petri Nets called Transformation Nets providing an **integrated view** on all the artefacts involved in a model transformation
- A dedicated **framework** called **TROPIC** will be provided allowing the **specification** and usage of mapping operators for certain model transformation scenarios as well as the actual **execution** and **debugging** of transformations, either in a standalone manner or as a front-end for other model transformation languages

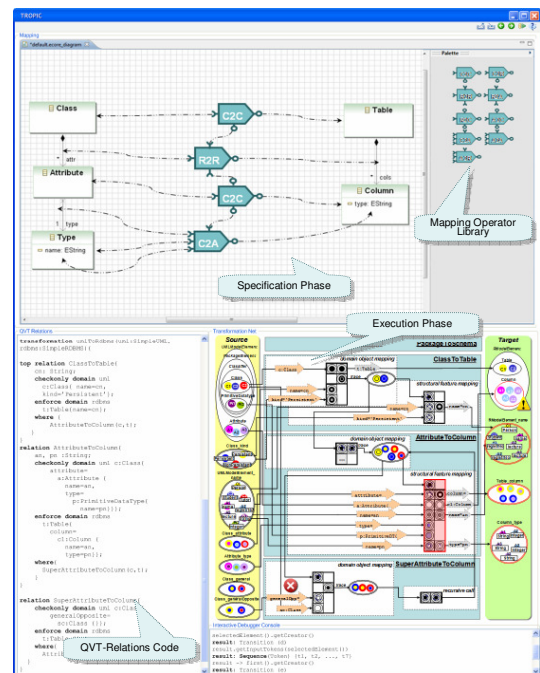

## Project Facts

- Start:** 03/2009
- End:** 02/2012
- Project No.:** P21374-N13
- Personnel:** 2 PhD students

## Contact

**Prof. Dr. Gerti Kappel**  
Business Informatics Group  
Institute of Software Technology  
and Interactive Systems  
Vienna University of Technology  
Favoritenstraße 9-11/188-3  
1040 Vienna, Austria  
kappel@big.tuwien.ac.at



## Project Partners

- Vienna University of Technology, Austria
- Johannes Kepler University Linz, Austria

This work has been partly funded by the Austrian Science Fund (FWF) under grant P21374-N13.

## Evaluation

- Case Studies** from diverse modeling domains (e.g., structural and behavioral) will be carried out for evaluating the **expressivity** of the mapping operators provided by the TROPIC library
- Empirical Studies** will be conducted with 200 master students of our MDE courses for evaluating the **non-functional** characteristics of TROPIC
- Collaborative Studies** with three international project partners, being the inventors of other model transformation languages (Prof. Dr. Jean Bézivin, Prof. Dr. Andy Schürr) as well as of Coloured Petri Nets (Prof. Dr. Kurt Jensen), will be performed in the form of **dedicated workshops**, thereby evaluating the features of TROPIC